

Model

**SMP**

# Cassetta con Serbatoio a membrana *Cabinet with bladder tank*

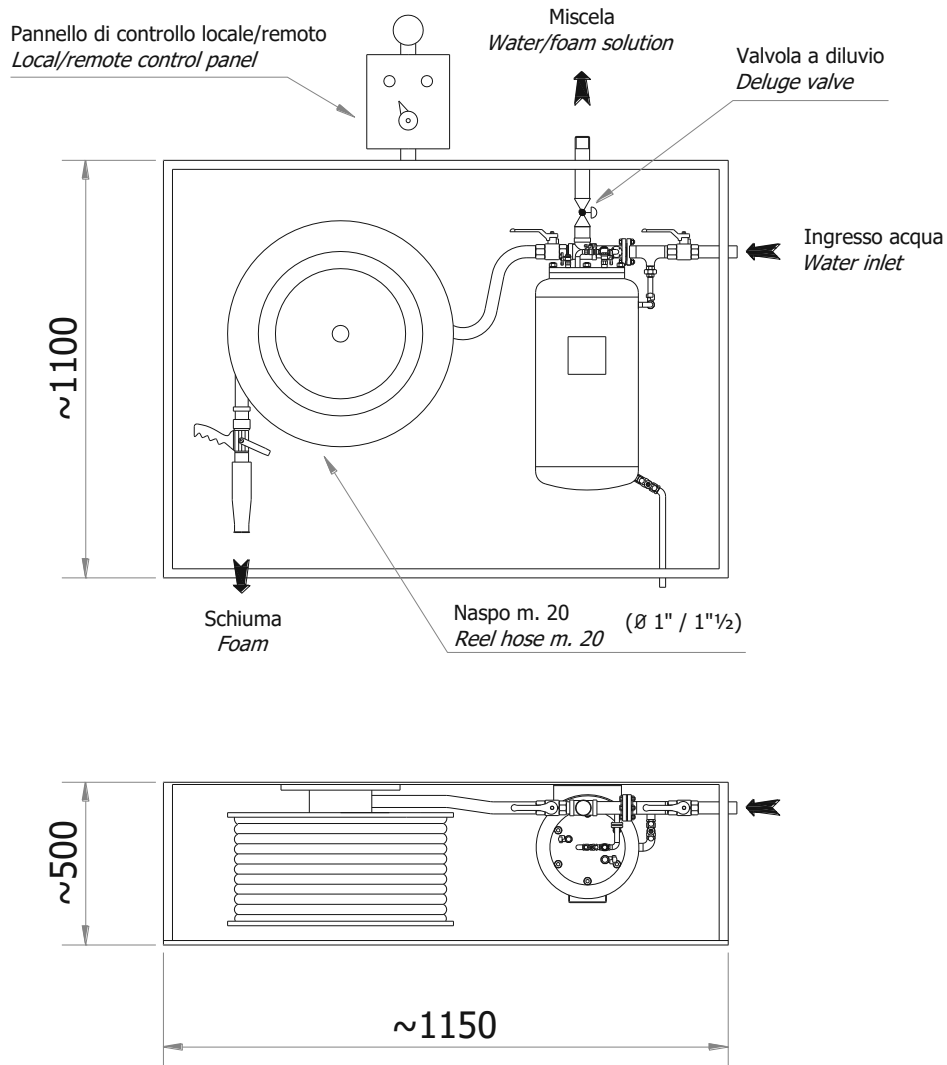

## Specifiche – Specifications

Caratteristiche costruttive, materiali, vedi la sezione 1-1	Construction features, materials, see the section 1-1
Capacità serbatoio: 25 ÷ 50 l.	Tank capacity: 25 ÷ 50 l.
Miscelatore $\varnothing 1''$ (portata: 70÷100 l/min al 1÷3%)	Mixer $\varnothing 1''$ (flow rate: 70÷100 l/min at 1÷3%)
Miscelatore $\varnothing 1\frac{1}{2}''$ (portata: 70÷300 l/min al 1÷3%)	Mixer $\varnothing 1\frac{1}{2}''$ (flow rate: 70÷300 l/min at 1÷3%)
Pressione di lavoro: min 3 bar	Working pressure: min 3 bar
Peso: 60 kg (25 l), 80 kg (50 l)	Weight: 60 kg (25 l), 80 kg (50 l)

## Certificazioni - Certifications

CE