

Serbatoio verticale a membrana con miscelatore ampio raggio

Vertical Bladder tank with wide range mixer

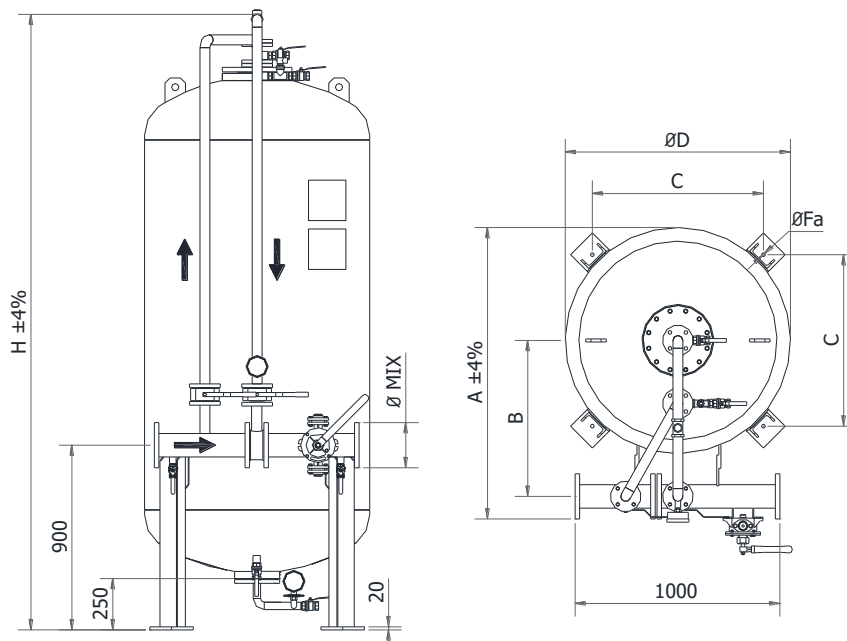

Model
SMV-MAP



Capacità, lt Capacity, lt	A	B	A	B	A	B	A	B	ØD	H	C	Fa	Peso, kg* Weight, kg*
	MAP-80		MAP-100		MAP-150								
1000	1310	695	1335	710	1390	740			1000	2360	760	18	313
1500	1310	695	1335	710	1390	740			1000	3010	760	18	370
2000	1410	695	1435	760	1490	790			1100	3221	830	18	520
	MAP-80 /100		MAP-150		MAP-200		MAP-250						
2500	1510	805	1530	845	1635	865	1635	935	1200	3361	920	26	671
3000	1710	905	1790	945	1835	965	1990	1030	1400	3322	1065	26	850
3500	1710	905	1790	945	1835	965	1990	1030	1400	3572	1065	26	925
4000	1910	1005	1990	1045	2045	1075	2200	1140	1600	3273	1210	26	995
4500	1910	1005	1990	1045	2045	1075	2200	1140	1600	3473	1210	26	1050
5000	1910	1005	1990	1045	2045	1075	2200	1140	1600	3674	1210	26	1320
5500	2060	1080	2140	1120	2195	1120	2350	1215	1750	3554	1350	26	1350
6000	2060	1080	2140	1120	2195	1120	2350	1215	1750	3753	1350	26	1370
6500	2210	1205	2395	1250	2445	1275	2600	1340	2000	3375	1500	30	1630
7000	2210	1205	2395	1250	2445	1275	2600	1340	2000	3476	1500	30	1680
7500	2210	1205	2395	1250	2445	1275	2600	1340	2000	3626	1500	30	1760
8000	2210	1205	2395	1250	2445	1275	2600	1340	2000	3827	1500	30	2000
8500	2210	1205	2395	1250	2445	1275	2600	1340	2000	3977	1500	30	2100
9000	2210	1205	2395	1250	2445	1275	2600	1340	2000	4128	1500	30	2300
10000	2210	1205	2395	1250	2445	1275	2600	1340	2000	4478	1500	30	2490
11000	2210	1205	2395	1250	2445	1275	2600	1340	2000	4779	1500	30	2640
12000	2210	1205	2395	1250	2445	1275	2600	1340	2000	5129	1500	30	2760

* I pesi sono indicativi riguardano i serbatoi a membrana senza mixer; peso del miscelatore vedi sezione 1-12,1-13.

* Approximate weight of bladder tank without mixer; for the mixer weight see section 1-12,1-13.

Specifiche – Specifications

Caratteristiche costruttive, materiali, vedi la sezione 1-1	Construction features, materials, see the section 1-1
Connessioni flangiate: dipendono dalla richiesta del cliente o dalla misura del miscelatore.	Flange connection depends on customer request or to the mixer size.
Diverso diametro del miscelatore su richiesta.	Dimensions for another mixer sizes on request

Certificazioni - Certifications



Serbatoio verticale a membrana con miscelatore ampio raggio

Vertical Bladder tank with wide range mixer



Model
SMV-MAP

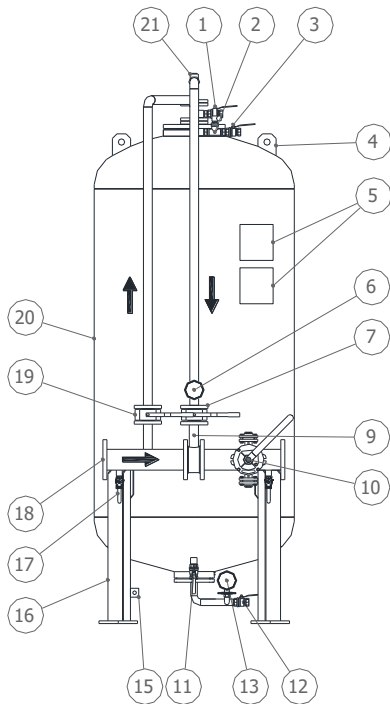

Legenda / Legend

- | | |
|----|---|
| 1 | Valvola di sfiato schiumogeno /
Foam concentrate side vent valve |
| 2 | Valvola di sicurezza / Safety valve |
| 3 | Valvola di sfiato acqua / Water side vent valve |
| 4 | Golfare / Lifting lug |
| 5 | Porta targa / Name plate support |
| 6 | Manometro serbatoio / Tank pressure gauge |
| 7 | Valvola di intercettazione schiumogeno /
Foam concentrate line isolation valve |
| 8 | Miscelatore model "MAP" / Mixer model "MAP" |
| 10 | Pompa di caricamento schiumogeno manuale /
Manual foam concentrate filling pump |
| 11 | Valvola di drenaggio acqua / Water side drain valve |
| 12 | Valvola di caricamento e drenaggio schiumogeno /
Concentrate filling and drain valve |
| 13 | Indicatore di livello / Level indicator |
| 15 | Massa a terra/ Earth connection |
| 16 | Supporto del serbatoio / Tank support |
| 17 | Valvole di drenaggio miscelatore / Mixer drain valves |
| 18 | Tronchetti di connessione / Connection spool pipes |
| 19 | Valvola di intercettazione acqua / Water line isolation valve |
| 20 | Serbatoio a membrana / Bladder tank |
| 21 | Valvola di ritegno / Check valve |

P&ID

