

Serbatoio atmosferico a stoccaggio schiumogeno

Atmospheric Foam concentrate storage tank

Model

SS

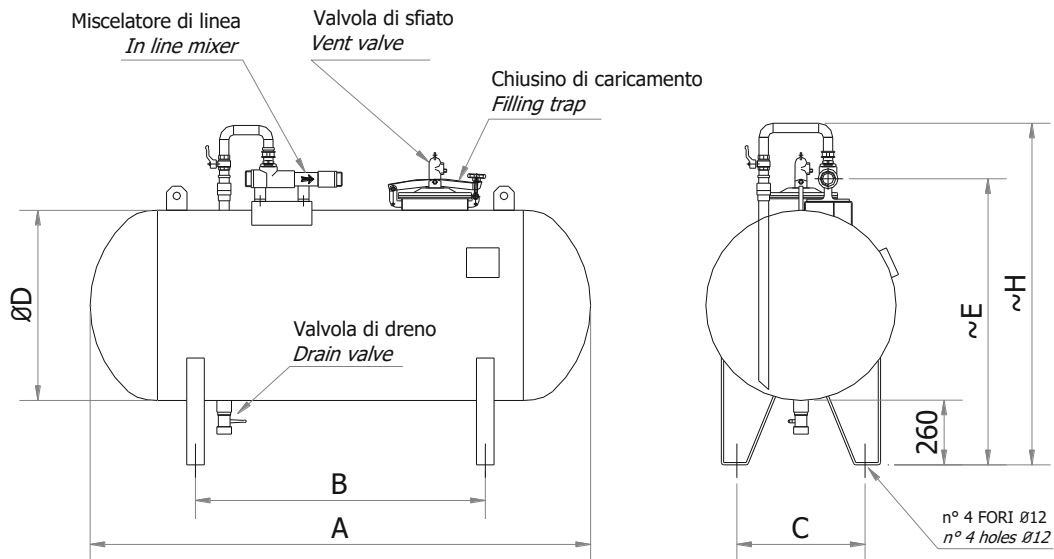

Modello Model	Capacità, lt Capacity, lt	A	B	C	ØD	E	H	Peso, kg* Weight, kg*
SS-2	200	1000	500	465	600	950	1150	93
SS-4	400	1550	900	465	600	950	1150	135
SS-6	600	1440	750	650	800	1150	1400	170
SS-10	1000	1500	750	760	1000	1350	1600	216

Specifiche – Specifications

Pressione di progetto: 1 bar + Prevalenza	Design pressure: 1 bar + Static head
Temperatura di progetto: -20 / +50 °C	Design temperature: -20 / +50 °C
Norma di riferimento: EN 13445-3	Design code: EN 13445-3
Serbatoio: acciaio al carbonio	Tank: carbon steel
Chiusino di caricamento: acciaio inox AISI 304	Filling trap: stainless steel AISI 304
Tubo pescante interno: acciaio inox AISI 304	Internal pick-up tube: stainless steel AISI 304
Miscelatori di linea modello MDL	In line mixer model MDL
Finitura: ciclo di verniciatura CSI#1 (vedi sezione 0-3-3-1)	Finish: coating cycle CSI#1 (see section 0-3-3-1)

A Richiesta – Optional

Norma di riferimento: ASME VIII div. 1	Design code: ASME VIII div.1
Serbatoio: acciaio inox AISI 304 o AISI 316	Tank: stainless steel AISI 304 or AISI 316
Capacità, apertura diverso dallo standard	Different capacities and openings

Certificazioni - Certifications

CE