

Model

**SME**

# Ugello schiuma media espansione Medium expansion foam nozzle

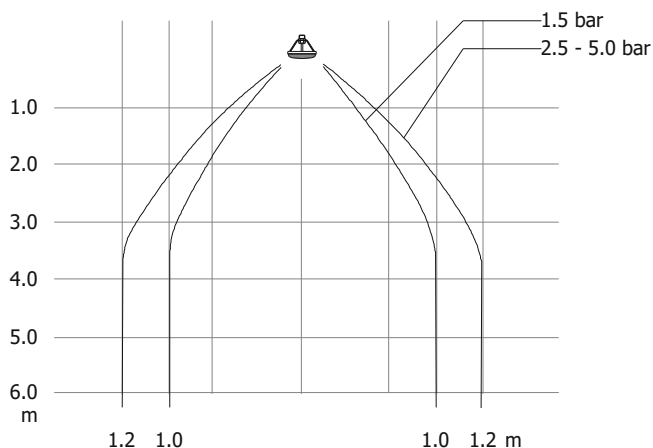
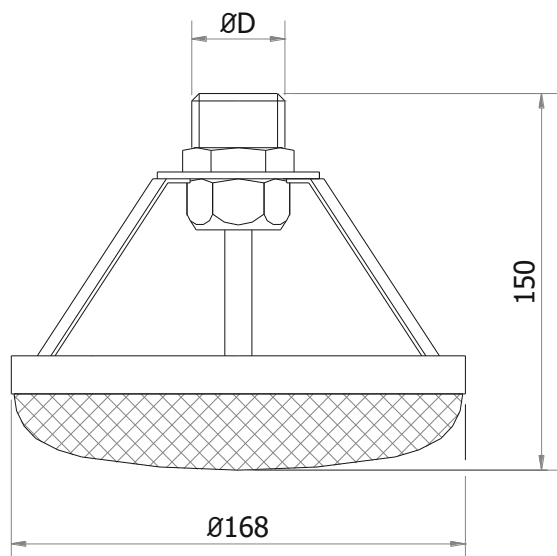

### Prestazioni – Performance

| Modello<br>Model | ØD<br>GAS-BSP M | Fattore k<br>k factor | Peso<br>Weight<br>gr |
|------------------|-----------------|-----------------------|----------------------|
| SME – K27        | ¾"              | 27                    | 700                  |
| SME – K45        | 1"              | 45                    | 750                  |

| Modello<br>Model | Portata / Flow rate        |    |    |    | Rapporto d'espansione / Expansion ratio * |    |    |    |
|------------------|----------------------------|----|----|----|---|----|----|----|
|                  | Pressione / Pressure (bar) |    |    |    | Pressione / Pressure (bar)                |    |    |    |
|                  | 1                          | 2  | 3  | 4  | 1   | 2  | 3  | 4  |
| SME – K27        | 27                         | 39 | 47 | 54 | 40  | 52 | 58 | 56 |
| SME – K45        | 45                         | 63 | 78 | 90 | 40  | 54 | 61 | 61 |

\* - Dipende dal tipo di schiumogeno / Depending on foam concentrate type

### Specifiche – Specifications

|                              |                                |
|------------------------------|--------------------------------|
| Corpo: acciaio inox AISI 304 | Body: stainless steel AISI 304 |
| Ugello: ottone               | Nozzle: brass                  |

### A richiesta – Optional

|                              |                                |
|------------------------------|--------------------------------|
| Corpo: acciaio inox AISI 316 | Body: stainless steel AISI 316 |
|------------------------------|--------------------------------|

### Certificazioni - Certifications

According to  
**EN-133565-1**