

Model

MML

Monitore manuale a leva

Lever operated manual monitor

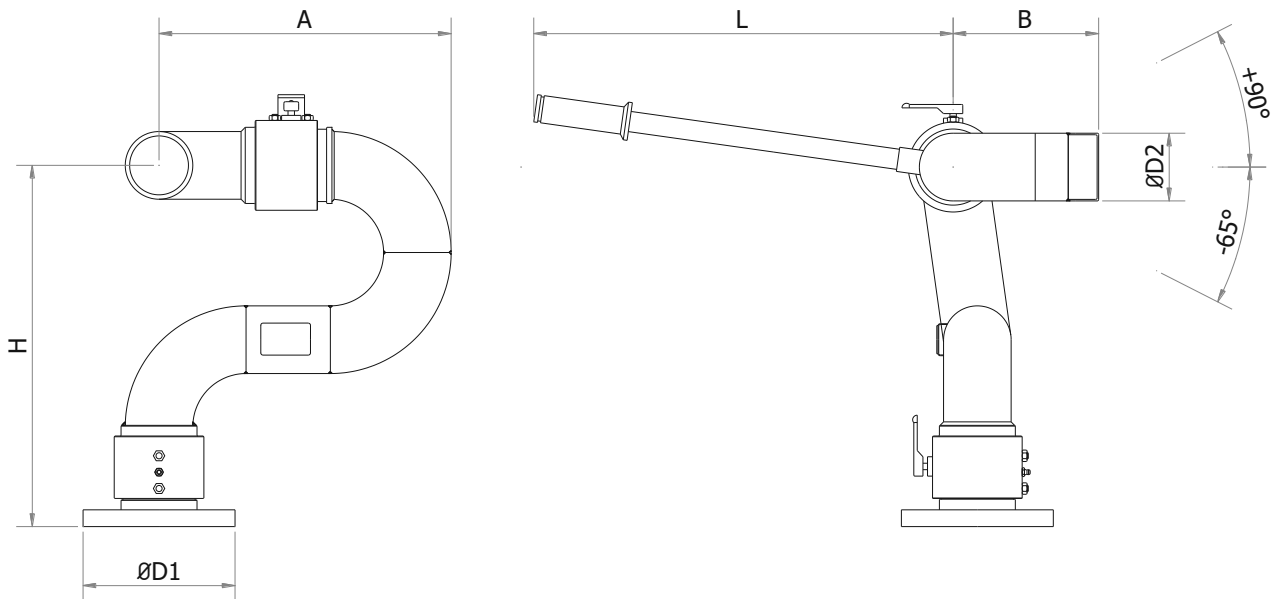

Modello Model	Corpo Body size	Portata max* max flow rate* l/min	Max. Forza di reazione Max.reaction force (kgF)	ØD1 ISO PN16 ANSI #150	ØD2 GAS-BSP M	A	B	L	H	Peso Weight kg
MML-65	2½"	2000	164	2½", 3", 4"	2½"	320	120	550	400	15
MML-80	3"	4000	330	3", 4", 6"	3"	385	164	550	475	21
MML-100	4"	7000	575	4", 6", 8"	4"	475	205	700	600	31

* raccomandato / recommended

Specifiche – Specifications

Pressione di progetto: 16 bar	Design pressure: 16 bar
Pressione di lavoro massima (consigliata): 12 bar	Max. working pressure (advised): 12 bar
Rotazione: 360° continua	Rotation: 360° continuous
Corpo: acciaio inox AISI 304	Body: stainless steel AISI 304
Giunti in acciaio inox AISI 304 montati su sfere in bronzo fosforoso e muniti di ingrassatori	Joints in stainless steel AISI 304 mounted on phosphor bronze balls and supplied with grease nipples
Flangia di base: acciaio al carbonio	Inlet flange: carbon steel
Finitura: ciclo di verniciatura CSI#2 (vedi sezione 0-3-3-2)	Finish: coating cycle CSI#2 (see section 0-3-3-2)
Perdita di carico : vedi la sezione 4-1-15	Pressure loss: see section 4-1-15

A richiesta – Optional

Flangia: acciaio inox AISI 304 o AISI 316	Inlet flange: stainless steel AISI 304 or AISI 316
Corpo: acciaio inox AISI 316	Body: stainless steel AISI 316

Certificazioni - Certifications

