

Model

MME 150-200

Monitore elettrico Electrical monitor

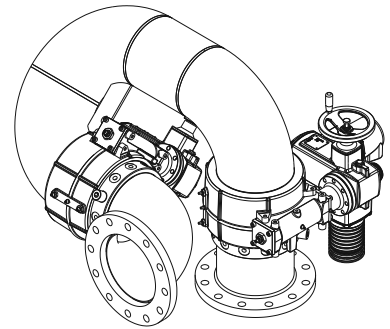
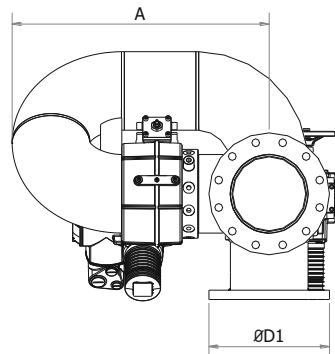
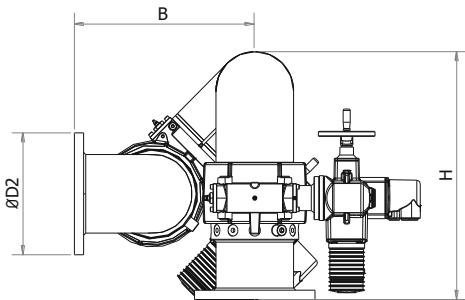

Modello Model	Corpo Body size	Portata max* max flow rate* l/min	ØD1 ISO PN16 ANSI #150	ØD2 ISO PN16 ANSI #150	A	B	H	Peso Weight kg
MME-150	6"	20000	6", 8", 10"	6"	600	410	540	144
MME-200	8"	30000	8", 10", 12"	8"	720	510	700	205

* raccomandato / recommended

Specifiche – Specifications

Pressione di progetto: 16 bar	Design pressure: 16 bar
Pressione di lavoro massima (consigliata): 12 bar	Max. working pressure (advised): 12 bar
Rotazione: 340° (velocità 16°/sec-dipende dall'attuatore)	Rotation: 340° (speed 16°/sec – depending on actuator)
Elevazione: +85°/-45° (+85°/-60° a richiesta)	Elevation: +85°/-45° (+85°/-60° optional)
Corpo: acciaio inox AISI 304	Body: stainless steel AISI 304
Motore AUMA®: 400V AC, 3F; 0,37 kW; IP 67	Motor AUMA®: 400V AC, 3ph; 0,37 kW; IP 67
Fine corsa elettrici / Potenziometro	Electrical end switch / Potentiometer
Giunti in acciaio inox AISI 304 montati su sfere in bronzo fosforoso e muniti di ingrassatori	Joints in stainless steel AISI 304 mounted on phosphor bronze balls and supplied with grease nipples
Flangia di base: acciaio al carbonio	Inlet flange: carbon steel
Finitura: ciclo di verniciatura CSI#2 (vedi sezione 0-3-3-2)	Finish: coating cycle CSI#2 (see section 0-3-3-2)
Perdita di carico: vedi la sezione 4-1-15	Pressure loss: see section 4-1-15

A richiesta – Optional

Flangia: acciaio inox AISI 304 o 316	Inlet flange: stainless steel AISI 304 or 316
Corpo: acciaio inox AISI 316	Body: stainless steel AISI 316
Motori con i voltaggi diversi	Motors with different voltages
Versione equipaggiata ATEX	ATEX Equipment version

Certificazioni - Certifications

