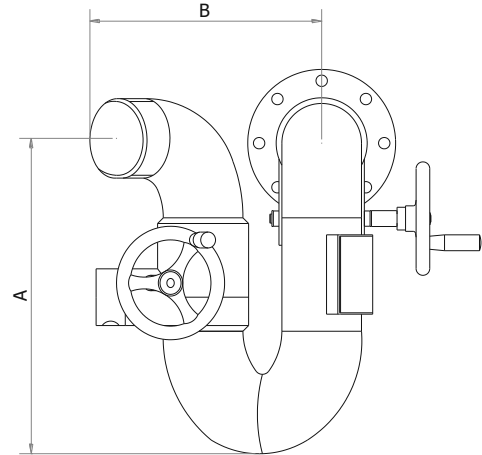
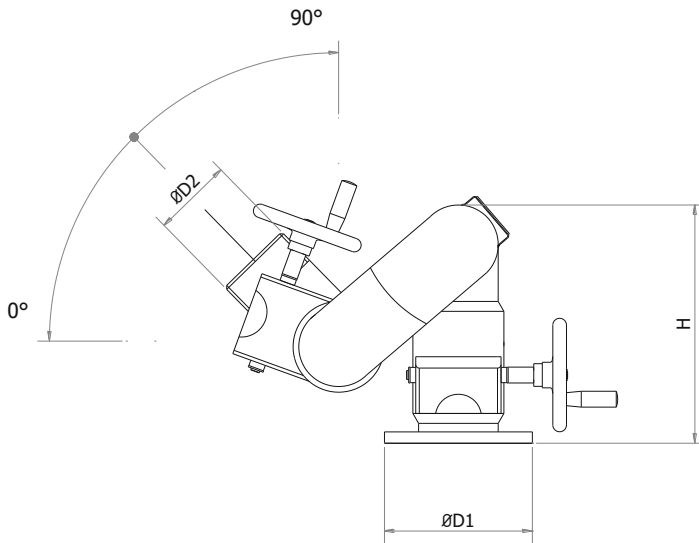

Model

Monitore manuale ribassato a 2 volantini**MM2V-RB****Lowered double hand wheel operated
manual monitor**

Modello Model	Corpo Body size	Portata max* max flow rate* l/min	Max. Forza di reazione Max.reaction force (kgF)	ØD1 ISO PN16 ANSI #150	ØD2 Gas BSP-M ISO PN16 ANSI #150	A	B	H	Peso Weight kg
MM2V-RB-80	3"	4000	330	3",4",6"	3", T	440	355	370	32
MM2V-RB-100	4"	7000	575	4",6",8"	4", T	530	460	425	36
MM2V-RB-125	5"	15000	1230	5",6",8"	5", T	580	420	500	65
MM2V-RB-150	6"	20000	1645	6", 8",10"	6", F	600	410	540	120
MM2V-RB-200	8"	30000	2468	8",10",12"	8", F	720	510	700	182

* raccomandato / recommended , T=Filettata/ Threaded Gas BSP-M, F= Flangiata/ Flanged ISO PN 16/ANSI #150

Specifiche – Specifications

Pressione di progetto: 16 bar	Design pressure: 16 bar
Pressione di lavoro massima (consigliata): 12 bar	Max. working pressure (advised): 12 bar
Rotazione: 360° continua	Rotation: 360° continuous
Corpo: acciaio inox AISI 304	Body: stainless steel AISI 304
Giunti in acciaio inox AISI 304 montati su sfere in bronzo fosforoso e muniti di ingrassatori	Joints in stainless steel AISI 304 mounted on phosphor bronze balls and supplied with grease nipples
Flangia di base: acciaio al carbonio	Inlet flange: carbon steel
Finitura: ciclo di verniciatura CSI#2 (vedi sezione 0-3-3-2)	Finish: coating cycle CSI#2 (see section 0-3-3-2)
Perdita di carico : vedi la sezione 4-1-15	Pressure loss: see section 4-1-15

A richiesta – Optional

Flangia: acciaio inox AISI 304 o 316	Inlet flange: stainless steel AISI 304 or 316
Corpo: acciaio inox AISI 316	Body: stainless steel AISI 316

Certificazioni - Certifications