

Model
BPN-2

Bocchello getto pieno/nebulizzato

Full jet / Fog nozzle

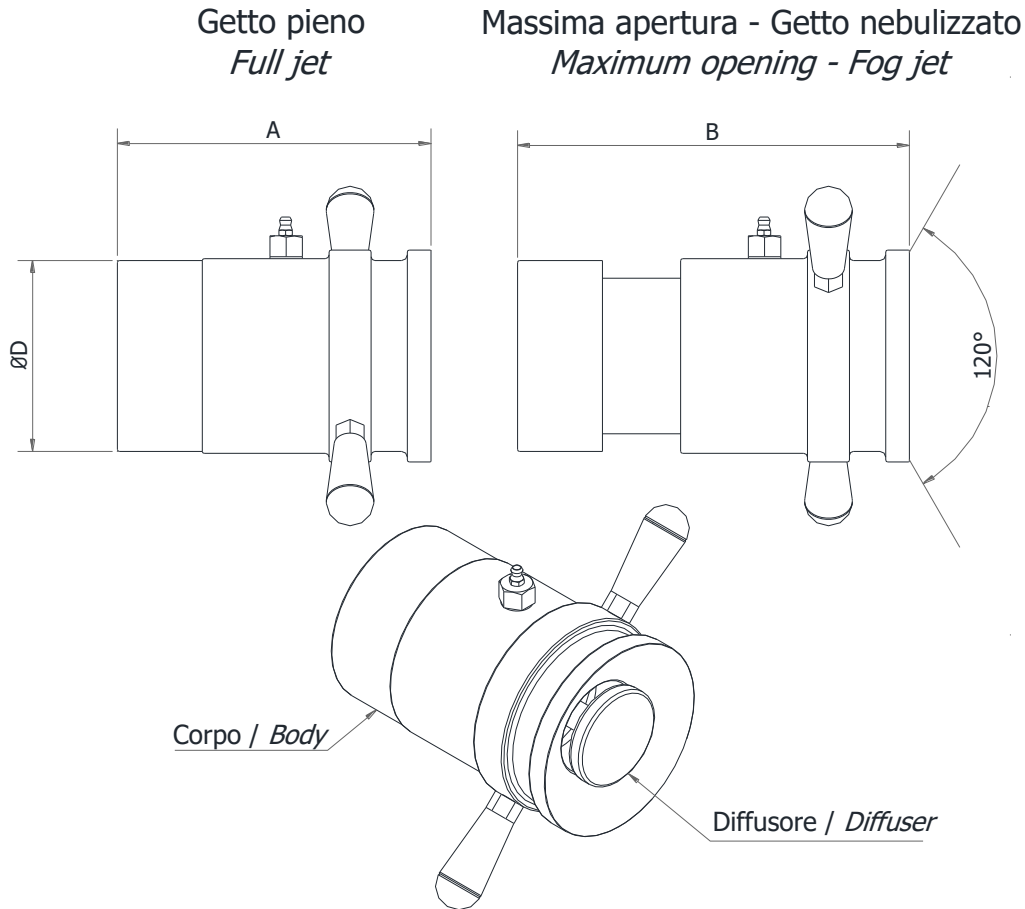

Modello Model	Portata a 7 bar flow rate at 7 bar l/min	ØD GAS-BSP F	A	B	Peso Weight kg
BPN-2-10	1000	2 ½" - 3"	165	205	8
BPN-2-15	1500	2 ½" - 3"	165	205	8
BPN-2-20	2000	2 ½" - 3"	165	205	8
BPN-2-25	2500	3"	165	205	8
BPN-2-30	3000	3"	165	205	8

Specifiche – Specifications

Corpo: acciaio inox AISI 304	Body: stainless steel AISI 304
Diffusore : bronzo	Diffuser : bronze
Finitura: Naturale	Finish : Natural

A richiesta – Optional

Corpo: acciaio inox AISI 316	Body: stainless steel AISI 316
Portate diverse su richiesta	Different flow rates on request

Certificazioni - Certifications



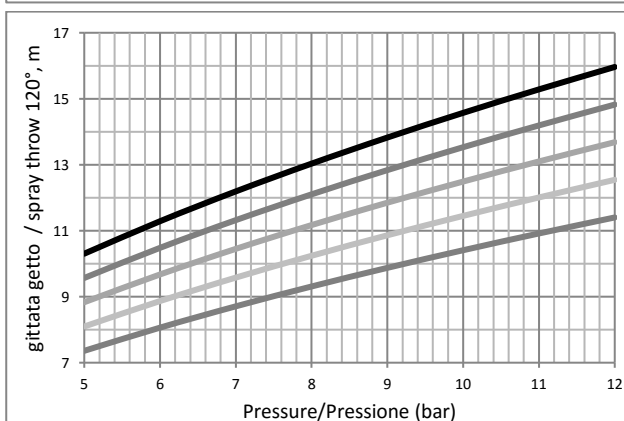
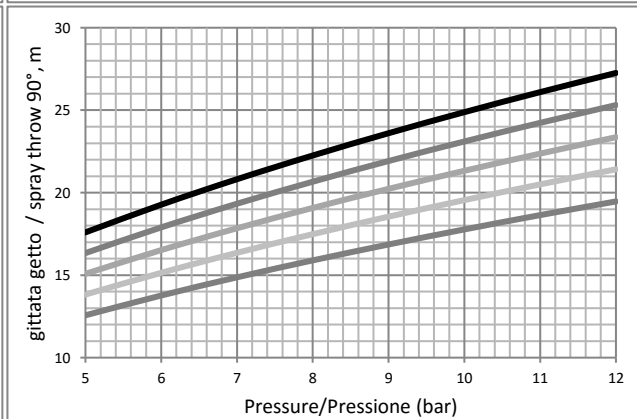
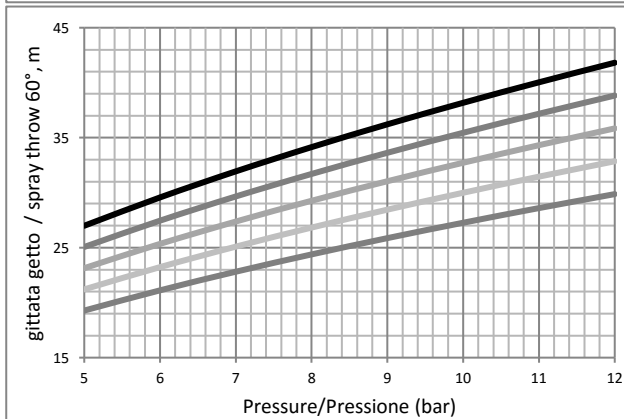
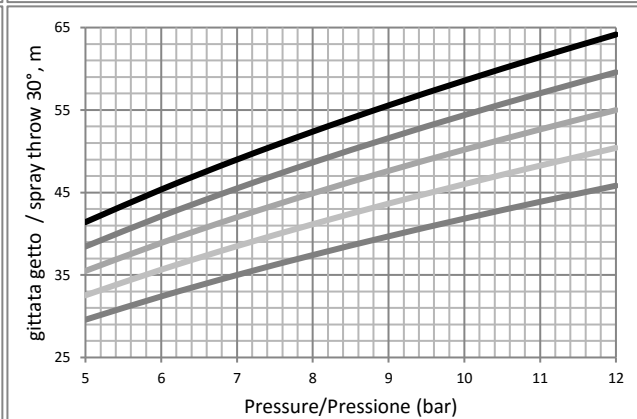
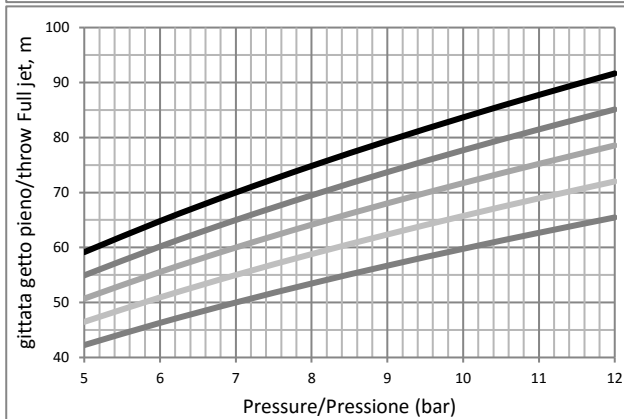
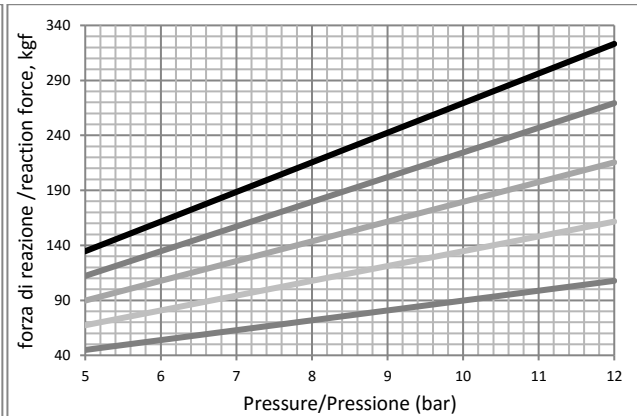
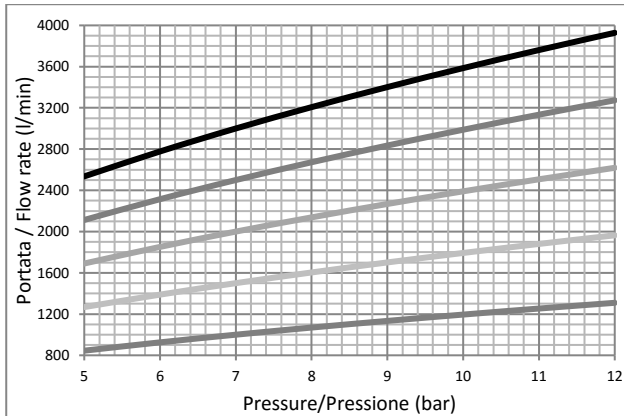

Ordine di lettura dei grafici
Graphics reading order



- BPN-2-30
- BPN-2-25
- BPN-2-20
- BPN-2-15
- BPN-2-10

Vedi sezione 4-2-0 per ulteriori informazioni / See section 4-2-0 for additional information